

48" (sealing
length 87in)

Norclamp
Split ®

Technical datasheet

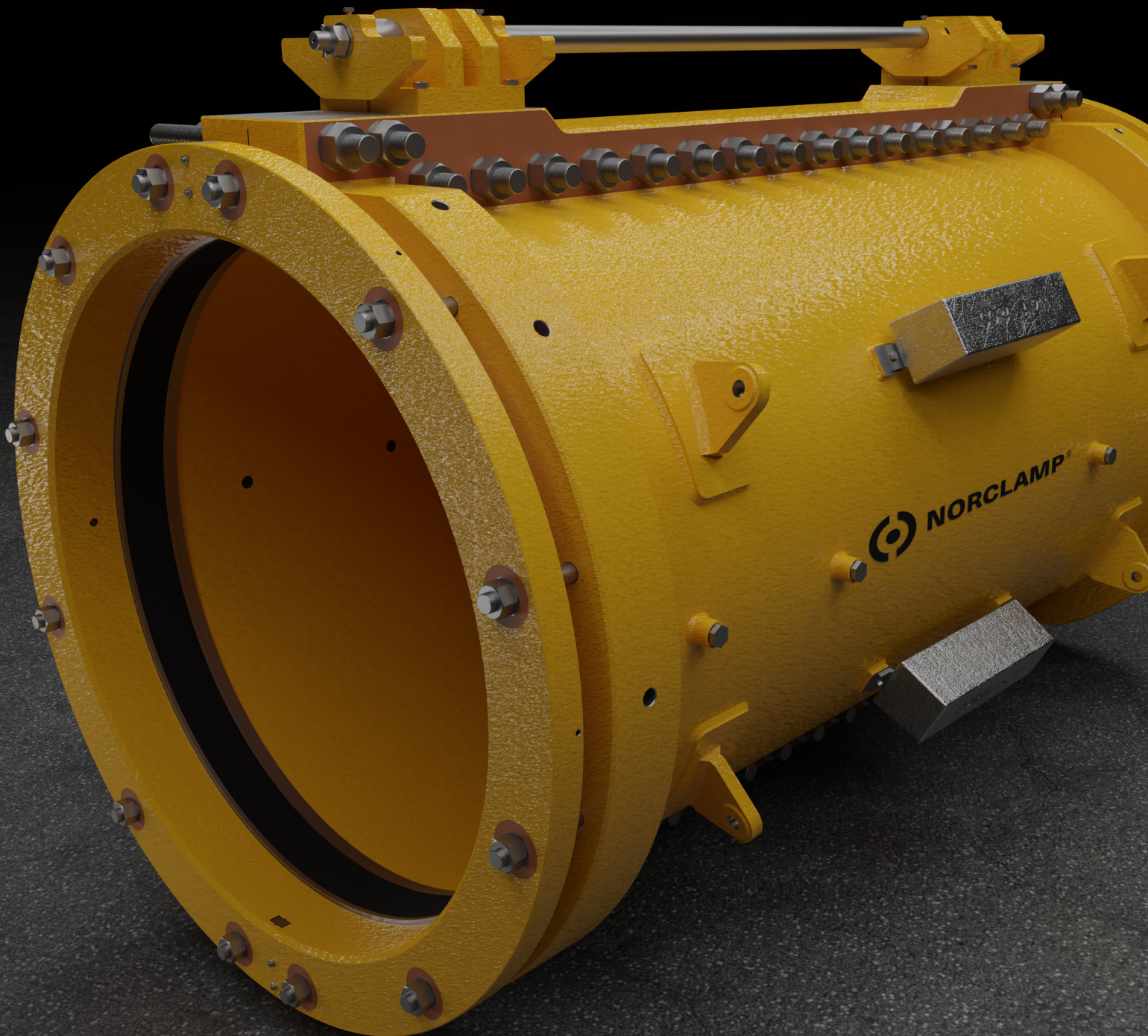

About

The Norclamp clamp family represents the epitome of Norway's renowned subsea technology solutions, developed through decades of engineering innovation to withstand harsh weather, deep waters, and strict regulatory standards. For over thirty years, our exceptional mechanical fittings have played a vital role in repairing and maintaining subsea pipelines across the globe.

The Norclamp clamp family has been designed to offer a seamless solution for sealing pipeline leaks and reinforcing weakened pipeline walls without the need for costly shutdowns or production losses. Thanks to its pioneering engineering, installation is swift and effortless.



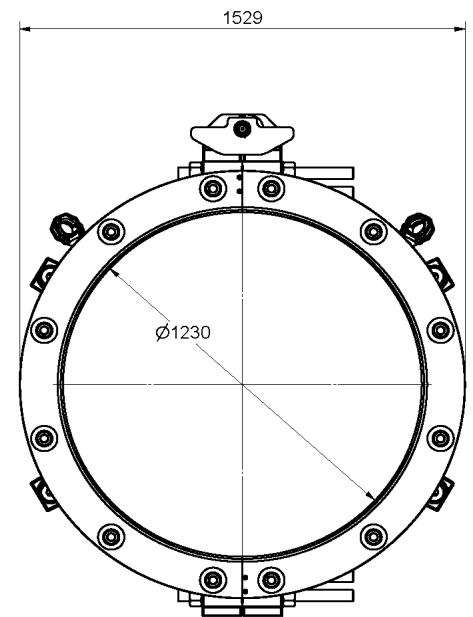
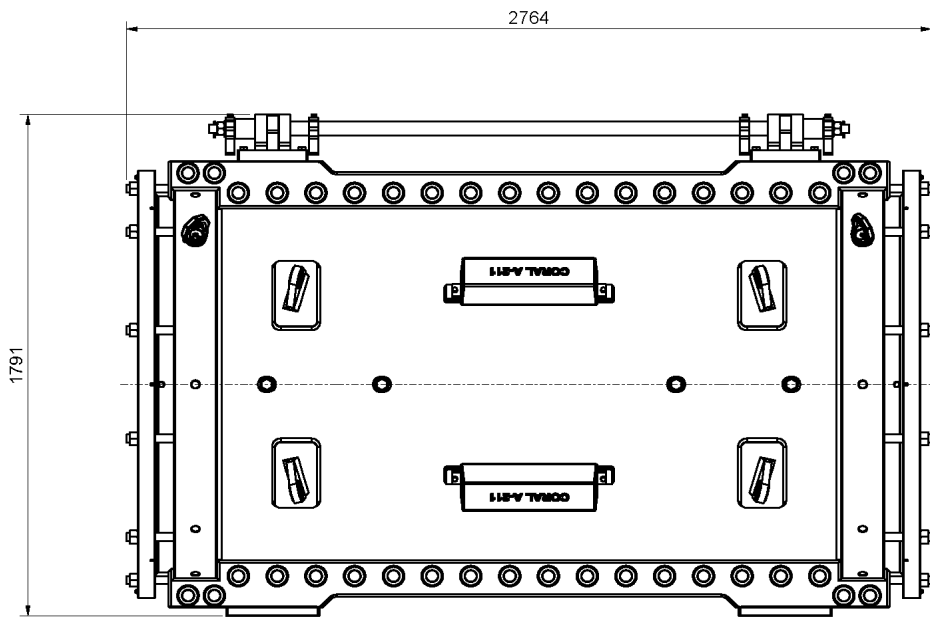

Technical data

The Norclamp Split is designed and built based on the traditional principle of a two-part clamp, with a compression packer at each end which forms a seal against the pipeline and a face seal between the two clamp halves.

The packers between the clamp and the pipeline are separately activated to handle pipeline ovality, grooves, out of roundness, roughness on the pipeline surface and still obtain a high integrity sealing.

Specifications

Pipeline size	48" (1219,2 mm)	Activation	Torque tool
Sealing length	87 in, 2212 mm	Seal material	H-NBR Shore 75A - 85A
Material	API-5L-X60	Design code	DNV-RP-F113
Temperature	-28°C to 121°C	Coating	Norsok M-501 System 7C
Working pressure	300 psi (20,7 barg)	Additional info	Clamp opening and closing by slings
Installation	Diver maximum 35 m of depth		